



Measurement Guideline

Issue Date: October 28, 2024

For more information, contact:

C-NLOPB
240 Waterford Bridge Road, Suite 7100
The Tower Corporate Campus – West Campus Hall
St. John's NL A1E 1E2
Tel: (709) 778-1400
Fax: (709) 778-1473

CNSOPB
201 Brownlow Avenue, Suite 27
Dartmouth NS B3B 1W2
Tel: (902) 422-5588
Fax: (902) 422-1799

ISBN #: 978-1-77865-016-1

Summary of Changes		
Date Revised	Sections (if applicable)	Description of Change
October 28, 2024	General	This Guideline has been placed in the new format and style; references to regulations have been updated; duplication has been removed with other guidelines and references to standards have been reviewed and updated, as necessary.

Foreword

The Canada-Nova Scotia Offshore Petroleum Board and Canada-Newfoundland and Labrador Offshore Petroleum Board (the *Regulators*) have issued this Guideline to assist operators in the design, construction and operation of metering systems for which *Regulator* approval is required pursuant to section 14 of the *Framework Regulations*.

Guidelines are developed to provide assistance to those with statutory responsibilities (including operators, employers, employees, supervisors, providers of services, suppliers, etc.) under the *Accord Acts* and regulations. Guidelines provide an understanding of how legislative requirements can be met. In certain cases, the goals, objectives and requirements of the legislation are such that no guidance is necessary. In other instances, guidelines will identify a way in which regulatory compliance can be achieved.

The authority to issue Guidelines and Interpretation Notes with respect to legislation is specified by sections 151.1 and 205.067 of the *Canada-Newfoundland and Labrador Atlantic Accord Implementation Act, S.C. 1987, c.3 (C-NLAAIA)*, sections 147 and 201.64 of the *Canada-Newfoundland and Labrador Atlantic Accord Implementation Newfoundland and Labrador Act, RSNL 1990 c. C-2*, subsection 156(1) and section 210.068 of the *Canada-Nova Scotia Offshore Petroleum Resources Accord Implementation Act, S.C. 1988, c.28 (CNSOPRAIA)* and section 148 and subsection 202BQ(1) of the *Canada-Nova Scotia Offshore Petroleum Resources Accord Implementation (Nova Scotia) Act*. The *Accord Acts* also state that Guidelines and Interpretation Notes are not deemed to be statutory instruments.

For the purposes of this Guideline, these Acts are referred to collectively as the *Accord Acts*. Any references to the C-NLAAIA, the CNSOPRAIA or to the regulations in this Guideline are to the federal versions of the *Accord Acts* and the associated regulations.

TABLE OF CONTENTS

1.0	ACRONYMS AND ABBREVIATIONS	6
2.0	DEFINITIONS	6
3.0	PURPOSE AND SCOPE	7
4.0	REQUIREMENTS	7
4.1	Compliance Verification	8
4.1.1	Regulator	8
4.1.2	Certifying Authority	9
4.1.3	Third Party	9
4.2	Innovations	9
4.3	Flexibility for Marginal Cases	10
5.0	PURPOSE FOR WHICH MEASUREMENT IS REQUIRED	11
6.0	CATEGORIES OF MEASUREMENT SYSTEMS	11
6.1	Overview of Measurement Categories	12
6.2	Measurement Uncertainty	13
6.3	Fiscal Quality Measurement	15
6.4	Field or Platform Allocation	16
6.5	Well Allocation Measurement	17
6.6	Fuel Gas, Gas Injection and Utility Gas	17
6.7	Produced Water and Water Injection	17
6.8	Drill Cuttings and Waste Fluid Injection	17
7.0	STANDARDS	17
8.0	DOCUMENTATION REQUIREMENTS	18
8.1	Flow System	18
8.2	Flow Calculation Procedure	19
8.3	Flow Allocation Procedure	19
8.4	Other submission requirements	19
9.0	PLANT BALANCES	20
10.0	MEASUREMENT OF LIQUID PETROLEUM	20
10.1	Fiscal Quality Measurement of Petroleum Liquids	21
10.1.1	Mode of Measurement	21
10.1.2	Meters and Associated Piping Systems	21
10.1.3	Secondary Measurements	22
10.1.4	Prover Loops and Sphere Detectors	22
10.1.5	Recirculation Facilities	23
10.1.6	Pulse Transmission (PD and Turbine Meters)	24
10.1.7	Totalisers and Compensators	24
10.1.8	Other Instrumentation	25
10.1.9	Security	26
10.1.10	Calibration Facilities	26
10.2	Field or Platform Allocation	26
10.2.1	Continuous Measurement	27
10.2.2	Intermittent Measurement	28
10.3	Well Allocation and Reservoir Management – Test Separator	29
11.0	MEASUREMENT OF GAS	30
11.1	Fiscal Quality Measurement of Gas	31
11.1.1	Mode of Measurement	31
11.1.2	Design Criteria	32
11.1.3	Computers and Compensators	34
11.1.4	Calculation of Design Uncertainties	35

11.2	Field or Platform Allocation	36
11.2.1	Dry Gas Measurement	36
11.2.2	Wet Gas Measurement	37
11.3	Well Allocation and Reservoir Management – Test Separator	38
11.4	Utility, Gas Injection and Fuel Gas Measurement	39
11.5	Flare or Vent Gas Measurement	39
12.0	MULTIPHASE PETROLEUM	40
12.1	Fiscal Quality Measurements of Multiphase Petroleum	40
12.2	Field or Platform Allocation	40
12.3	Well Allocation	41
12.4	Standards	42
13.0	PRODUCED AND INJECTED WATER	42
14.0	DRILL CUTTINGS AND WASTE FLUID INJECTION AND MEASUREMENT	43
15.0	OPERATING PROCEDURES	43
15.1	Hydrocarbon Liquid Measurement Systems	43
15.1.1	Prover Calibration	43
15.1.2	Determination of Meter Characteristics	44
15.1.3	Meter Proving in Service	45
15.1.4	Meter Factors	45
15.2	Gaseous Measurement Systems	46
15.2.1	Pre-Commissioning	46
15.2.2	Start-up Precautions	46
15.2.3	Differential Pressure Measurement	47
15.2.4	Ancillary Instrumentation	47
15.2.5	Inspection of Orifice Plates and Meter Tubes	48
15.2.6	Other Meters	49
15.3	Multiphase Measurement Systems	49
15.4	General Procedures	50
15.4.1	Documentation at the Meter Station	50
15.4.2	Direct Reporting to the Regulator	51
16.0	BIBLIOGRAPHY	52

1.0 Acronyms and Abbreviations

API	American Petroleum Institute
BS&W	Basic Sediment and Water
CCO	Chief Conservation Officer
C-NLAAIA¹	<i>Canada-Newfoundland and Labrador Atlantic Accord Implementation Act</i>
C-NLOPB	Canada-Newfoundland and Labrador Offshore Petroleum Board
CNSOPB	Canada-Nova Scotia Offshore Petroleum Board
CNSOPRAIA²	<i>Canada-Nova Scotia Offshore Petroleum Resources Accord Implementation Act</i>
FSA	Flow System Application
GOR	Gas Oil Ratio
ISO	International Organisation for Standardisation
LGR	Liquid Gas Ratio
LPG	Liquid Petroleum Gas
NL	Newfoundland and Labrador
NS	Nova Scotia

2.0 Definitions

In this Guideline, the terms such as “authorization”, “chief conservation officer”, “conservation officer”, “development plan”, “development well”, “operator” and “waste”, referenced herein have the same meaning as in the *Accord Acts*.³

Refer also to defined terms in the *Framework Regulations*.

¹ References to the C-NLAAIA in this Guideline are to the federal version of the *Accord Act*

² References to the CNSOPRAIA in this Guideline are to the federal version of the *Accord Act*

³ C-NLAAIA 2, 135; CNSOPRAIA 2, 138

For the purposes of this Guideline, the following terms have been capitalized and italicized when used throughout. The following definitions apply:

<i>Accord Acts</i>	means the <i>Canada-Nova Scotia Offshore Petroleum Resources Accord Implementation Act</i> and <i>Canada-Nova Scotia Offshore Petroleum Resources Accord Implementation (Nova Scotia) Act</i> , <i>Canada-Newfoundland Atlantic Accord Implementation Act</i> and the <i>Canada-Newfoundland and Labrador Atlantic Accord Implementation (Newfoundland and Labrador) Act</i>
<i>Framework Regulations</i>	means the <i>Canada-Newfoundland and Labrador Offshore Area Petroleum Operations Framework Regulations, SOR/2024-25</i> and the <i>Canada-Nova Scotia Offshore Area Petroleum Operations Framework Regulations, SOR/2024-26</i>
<i>Good Oilfield Practices</i>	means those practices, methods, standards and procedures generally accepted and followed by prudent, diligent, skilled and experienced personnel in petroleum exploration, development and production operations
<i>Regulator</i>	means the Canada-Newfoundland and Labrador Offshore Petroleum Board or the Canada-Nova Scotia Offshore Petroleum Board, as the case may be

3.0 Purpose and Scope

The objective of this Guideline is to assist operators in the submission of a flow system, flow calculation procedure and flow allocation procedure for approval for a production project pursuant to section 14 of the *Framework Regulations*. Additional guidance is also provided in section 14 of the *Framework Guideline*. For the purposes of this Guideline, this application is referred to as the Flow System Application (FSA).

4.0 Requirements

Requirements for measurements and flow systems are provided in sections 74 – 78 of the *Framework Regulations*. In accordance with these sections, all produced and injected fluids (which means gas or liquid, or gas and liquid in combination) are to be measured and, where appropriate, allocated in accordance with a flow system, flow calculation and allocation procedures which have been approved by the *Regulator*. Since the Governments of NL and NS are royalty owners, the respective *Regulator* will consult government officials on the suitability of the transfer meter.

Additionally, the following should be taken into consideration in the development of an FSA:

- Provisions of the *Accord Acts*⁴, prohibiting waste.
- Sections 79 – 85 of the *Framework Regulations* respecting Production Conservation.
- Sections 194, 196, 197, 198 and 202 of the *Framework Regulations* requiring operating and production records and reports.

Where petroleum is delivered to shore via a pipeline which serves as a common transportation route for a number of fields then the “method of measurement” will include the measurement of petroleum at the terminal serving the relevant pipeline and the allocation procedures used to determine each contributing field’s share of the petroleum used at or exported from the terminal.

In order to assist an operator in determining the purpose and selecting a measurement category, the operator should contact the *Regulator* at an early stage in the consideration of the development (i.e., at the development plan stage). It is recommended that the operator submit a metering philosophy document to the *Regulator* either at this stage or once the system has been designed such that clarification can be provided, where necessary, with respect to measurement requirements.

4.1 Compliance Verification

The following compliance verification activities may be undertaken:

4.1.1 Regulator

Conservation officers may, at their discretion, review the metering systems at any stage from construction through commissioning. During operation, operators can expect the flow system and flow calculations and allocation procedures to be routinely verified by conservation officers to satisfy the *Regulator*.

As the royalty owners, the provincial governments of NL and NS have various agreements and legislation concerning the calculation of their royalty share. The accurate recording and reporting of petroleum volumes is critical to this calculation. Therefore, the governments of NL and NS reserve the right to participate fully in any verification activity, including the witnessing and approvals of custody transfer meters. In addition, the CCO will provide copies of all relevant documents and will liaison with the provincial government concerning custody transfer meters.

⁴ C-NLAAIA 154; CNSOPRAIA 159

4.1.2 Certifying Authority

The design and associated inspection, testing and maintenance of the flow system is also included in the Certification Plan and Scope of Work of the Certifying Authority. Refer to the requirements and associated guidance under Part 5 of the *Framework Regulations*.

4.1.3 Third Party

The *Regulator* may also require a third party audit of the flow system design or associated procedures at the following stages:

- prior to initiating construction activities;
- prior to initial use of the flow system or procedures; or
- within six months of initiation of petroleum production.

The *Regulator* may also require third party audits during production operations. The third party audit will be either co-ordinated by the *Regulator* or the operator. In either case, all costs are to be paid by the operator. When the *Regulator* directs the operator to coordinate the third party audit, prior to conducting the audit, the operator should provide the audit scope and a potential list of auditors to the *Regulator* for approval. A copy of all third party audit reports should be provided to the *Regulator* and the operator.

4.2 Innovations

If an operator wishes to use new technology or to deploy existing technology in a novel setting then the operator should refer to the requirements and associated guidance for innovations under section 103 of the *Framework Regulations*. As part of this process, it is requested that the operator provide full justification to the *Regulator* and the Certifying Authority, as applicable. The objectives, design, methodology and acceptance criteria of any technology qualification program for the flow system should be agreed in advance with the *Regulator*. The *Regulator* or the Certifying Authority, as applicable, should be given the opportunity to witness tests at their discretion and/or may request to be engaged during witness testing.

If it is proposed to use multiphase metering for fiscal intent it would be expected to perform as well as or better than the traditional test separator method. This technology is still at an early stage in its development and a concern is that the rate of development can be very rapid. Various standards bodies, both national and international, may be unable to produce standards or codes of practice on a time scale that would permit early deployment.

4.3 Flexibility for Marginal Cases

If an alternative technology or process can produce comparable results to existing measurement systems, such technologies may be considered for use in marginal cases. Examples of marginal cases could include, but are not limited to; marginally economic field developments, low flow rates, changes in rates over field life and possible relaxations of requirements justified through a track record of operating experience developed over time.

For example, in the case of a marginally economic field development, the requirement for three-phase separation to meet the highest standards of measurement only achievable on single phase fluids, has the potential to make such a development uneconomic. Therefore, when reviewing an operator's measurement proposals for a so called 'marginal' field, on an exception basis the *Regulator* may relax measurement requirements, as specified in this Guideline, in the interests of encouraging the development of these oil and gas reserves.

For such relaxation to be granted in the case of an economic argument, the *Regulator* will require economic justification from the operator. This should include the following:

- Details of the relevant field economic parameters (e.g., predicted production profiles and development costs).
- The measurement options considered (one of which will necessarily be a fiscal quality solution).
- The approximate cost to the project that would have been incurred by the installation of a fiscal quality measurement system and the economic justification for the rejection of this solution.
- The cost of the system actually proposed and the resultant savings in comparison with the fiscal quality solution.

In many cases the economics are so clear that there is little choice over which class of measurement is appropriate for a particular field development. However, other cases may present the operator with a difficult choice – whether to jeopardise revenue by the installation of a cheaper, but more uncertain, measurement system, or to reduce operational exposure to unfavourable systematic bias by investing money in higher-quality measurement.

The *Regulator* will generally advise the latter approach in such cases.

For other types of exception, operators may be able to technically demonstrate equivalence of results through an alternative approach or may be able to use track records of operations to justify relaxations.

5.0 Purpose for Which Measurement is Required

The first task in determining the suitability of a proposed measurement system or systems is to identify the purposes for which measurement is required. This includes:

- where measurements are to account for petroleum produced from the licensed area such as:
 - to safeguard revenues from royalty paying field; or
 - to allocate production from shared facilities to different fields or fiscal regimes;
- where measurements are to enable reservoir management, such as:
 - to track total reservoir volumes to determine recovery efficiency and to identify targets;
 - to improve the understanding of reservoir behaviour to enable effective reservoir management strategies to be implemented; or
 - to track volumes produced and injected for pressure maintenance and conservation of the total resource;
- to establish clearly whether a reservoir is no longer economically viable prior to initiating abandonment procedure; or
- for other purposes relevant to the licence, such as:
 - establishing the viability of a reservoir as a production prospect as for example with extended formation flow tests and pilot schemes;
 - measuring flare gas, fuel gas and utilities use;
 - monitoring the environment;
 - accounting for drill cuttings and waste fluids injected into a formation; or
 - measuring any other produced or injected fluids per the *Framework Regulations*.

6.0 Categories of Measurement Systems

This section is intended to provide an overview of measurement categories and measurement requirements. It is not possible to capture all cases and more details are provided in subsequent sections of this Guideline, but it should provide an overview of expectations for most normal operations. Though some examples are provided to add clarity, it should be noted that it has not been attempted to capture every possible case with an example. Within each category of measurement there will be scope to vary the detailed method of achieving the measurement objective.

At the early discussion stage, the operator and the *Regulator* will agree on the categorisation of a measurement system and associated accuracy requirements. For new field developments, the operator is encouraged to contact the *Regulator* early in the field development stage to discuss the appropriate measurement category. The measurement technique employed and its uncertainty, and the operating procedures used should be appropriate for the fluid and service in question. Rather than fitting a measurement category to a particular field, it is more appropriate to consider at the design stage the economics of a particular field and the standard of measurement that will be supported. This will indicate whether or not the project economics will support

separation and dedicated processing of fluids prior to their measurement and export. The *Regulator* will request operators to apply the best standard of measurement consistent with economic considerations.

Once the appropriate measurement category for a particular development has been agreed, this should be regarded as no more than a ‘first step’. Whatever the class of measurement system, the target uncertainty will only be met if adequate supporting measures are taken.

For example, uncertainty of better than 0.25% is potentially achievable if the system is installed, operated and maintained correctly.

The appropriate level of maintenance for a measurement system will of course depend on the ‘class’ of measurement desired. Fiscal quality systems will generally require the highest degree of attention.

6.1 Overview of Measurement Categories

For petroleum fluids, the *Regulator* considers three levels of metering accuracy shown in Table 1 below:

Table 1 - Categories of Measurement

	<u>Hydrocarbon</u> <u>Liquid</u>	<u>Hydrocarbon</u> <u>Gas</u>
Fiscal or custody transfer quality measurement	0.25 %	1 %
Field or platform allocation	1 %	3 %
Well allocation	5 %	5 %

The three categories of measurement are defined as follows:

- **Fiscal or Custody Transfer Quality Measurement** is required at points of custody transfer and at the export of the offshore system where the two points are different. The offshore system may include more than one connected production platform.
- **Field or Platform Allocation** denotes the accuracy required for the total flow from a system to be allocated to a single field or platform in a multi-field or platform development, where total flow is later measured further down the production stream by an approved fiscal quality meter, as described above.
- **Well Allocation** is the level of accuracy required for allocation of total flow to an individual well.

Following agreement with the *Regulator*, a flow system may not support fiscal quality measurement, even if it is a custody transfer point. In this case, where

fiscal quality would be normally required but has been exempted, then the lower quality measurement of field, platform or well allocation would be used for fiscal purposes.

An example of field allocation is discussed below and this discussion can be equally applied to well allocation, though accuracies will differ as shown in Table 1. Allocation accuracy is normally tracked on a day to day basis by proration factor. For example, if a platform accuracy of 3% is required for gas, then the proration factor of the measured fiscal volume to the sum of the measured platform flow volumes would ideally be 1.0, but may vary between 0.97 and 1.03, averaged on a volume per reporting period basis. Where proration factor is given by:

$$\text{Proration Factor} = \frac{\text{Actual Volume}}{\text{Estimated Volume}}$$

Actual volume is the accurate volume, measured by a more accurate meter, to be allocated and estimated volume is the sum of volumes from the less accurate meters. For example, in a multi-field development with several platforms, the field or platform proration factor would be calculated using the actual volume measured at the system export fiscal meter and the estimated volume would be the sum of the less accurately metered individual platform or field volumes. The volumes are to be for one report period, whether daily, monthly or as otherwise agreed.

For a platform with three wells, the well proration factor would be calculated using the actual volume as measured at the platform export and the estimated volume would be the sum of the three well metered or estimated volumes.

Though monitoring of the proration factor will be the means of tracking measurement performance on a regular basis, the design basis of the measurement system should also be able to demonstrate the required accuracies can be achieved (e.g., 3% for field or platform total gas metering, 5% for individual well metering).

6.2 Measurement Uncertainty

Table 2 – Overall Measurement Uncertainties

	Overall Measurement Uncertainty
Fiscal Quality, Oil	±0.25 %
Fiscal Quality, Gas	±1 %
Platform or Field Allocated Oil	±1 %
Platform or Field Allocated Gas	±3 %
Platform Produced Water	±4 %

Well Oil	±5 %
Well Gas	±5 %
Well Water	±5 %
Flaring	
(a) High Pressure Flare	±5 %
(b) Low Pressure Flare	±10 %
Fuel Gas	±3 %
Injection Water	±4 %
Gas Injection	±3 %
Waste Fluid Injection	±15 %
Utility Gas*	±3 %

*Utility gas is further defined in section 11.4 of this Guideline.

Note: Fiscal quality and platform, field and well allocation requirements are described in section 6.1 of this Guideline. Platform, field or well measurement may be required at fiscal quality, or may be used for fiscal purpose, if they are from separate royalty regimes or are the sole production source prior to export from the offshore. Again, if exceptions are required, early communication with the *Regulator* is recommended.

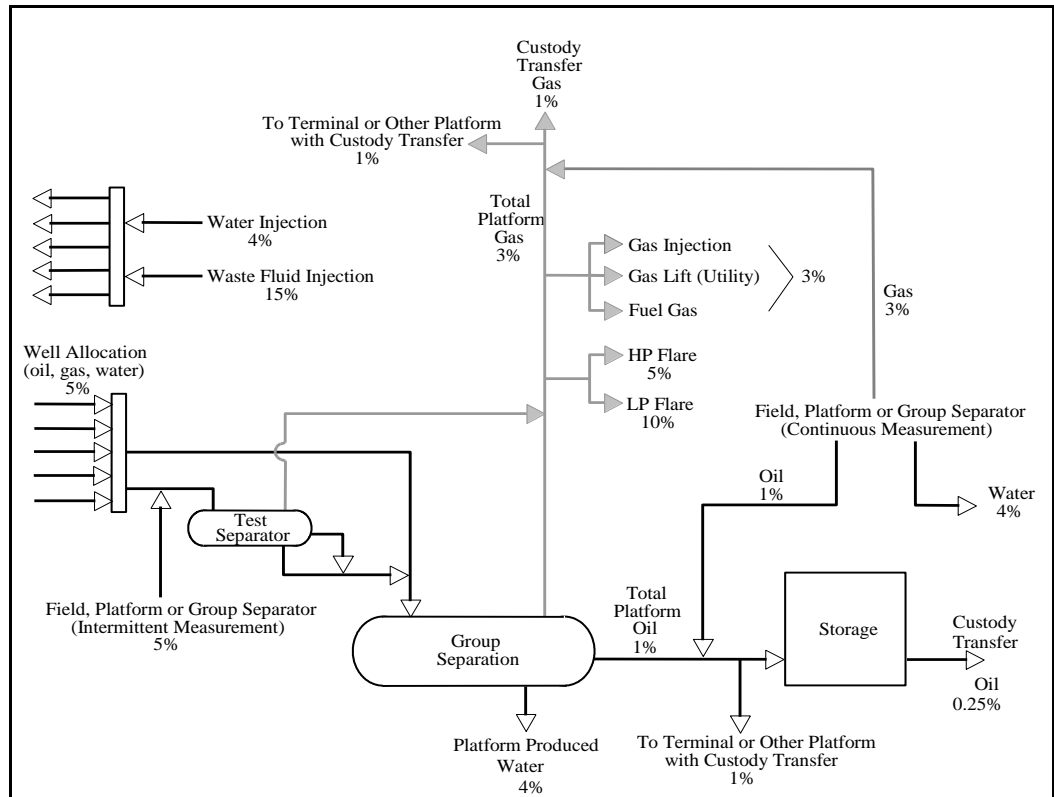

Figure 2 – Process Flow Diagram Showing Measurement Uncertainties

6.3 Fiscal Quality Measurement

The term fiscal in the context of measurement systems can have different definitions in different areas of the world. This section describes the term fiscal as it is applied throughout this Guideline. In its simplest definition, fiscal is the highest quality, or most accurate, measurement in the system. Though strictly speaking the term ‘fiscal metering’ implies a service, not a quality, it is used throughout this Guideline to also represent a quality.

‘Fiscal’ literally means ‘concerned with government finance’. Fiscal metering may therefore be defined as metering of fluids that will ultimately have an impact on government finance. Government revenue can be affected through:

- Royalty
- Corporation Tax

The first of these is levied more or less directly on production, the other on company profit – which is clearly related to production.

Within the jurisdiction of the *Regulator*, fiscal quality measurements are the highest quality of measurements required at any points of custody transfer and at the export point from offshore systems where the two measurement points are different.

A fiscal meter is any system, or element of that system, that is used to determine production rates that will ultimately generate revenue for an operator.

Depending on the particular allocation mechanism for a field, the term ‘fiscal’ can therefore potentially be applied to measurement of:

- Separator flow rates
- Well test flow rates
- Gas flared
- Fuel and utility gas
- Gas injected
- Hydrocarbon content in produced water discharged

It should be noted that though these measurements are not required to be made to fiscal quality accuracies as described in this Guideline, rather these measurements may be used for fiscal purposes.

The *Regulator* will require fiscal quality measurement, which by industry consensus is $\pm 0.25\%$ uncertainty for hydrocarbon liquid (i.e., oil, LPG, condensate) and $\pm 1.0\%$ for gas for all fields which contain a production facility which processes oil and gas prior to leaving the facility or at a point of custody

transfer. (The ‘facility’ may be a group of connected platforms). These are overall uncertainties and are derived from an appropriate statistical combination of the component uncertainties in the measurement system. The equipment used to achieve this level of performance will vary according to the particular circumstances of each development and any new technology should result in equal or lower uncertainties as discussed in section 4.2 of this Guideline.

6.4 Field or Platform Allocation

This category of measurement is usually taken to mean measurement by which a quantity of product which has been metered to a higher standard is attributed to different sources. Continuous measurement to an uncertainty not greater than $\pm 1.0\%$ would be required for liquid hydrocarbons and not greater than $\pm 3.0\%$ for hydrocarbon gases, provided that the overall larger uncertainties do not mask significant systematic errors which would introduce bias in the production accounting. Proration factors are expected to stay within the following ranges:

Fluid	Proration Factor Range
Hydrocarbon Liquid	0.99 to 1.01
Hydrocarbon Gas	0.97 to 1.03

The operator is expected to investigate the cause of proration factors outside these ranges. Proration factors will be monitored on a monthly basis following the submission of the monthly production reports pursuant to section 198 of the *Framework Regulations*. Following a request from the *Regulator*, operators will be required to report the cause and corrective measures being taken following repeated deviations outside the accepted ranges. Proration factors may be monitored more frequently than monthly at project start-ups or following periods of repeated deviations. Further details on reporting requirements are discussed in section 15.4.2 of this Guideline.

Platform water (produced, injected and water injected into the process stream) should be metered to an accuracy of $\pm 4\%$.

In the case where field economics do not support continuous measurement, ‘allocation by flow sampling’ will be considered on an exception basis. (This use of the term flow sampling should not be confused with the industry practice of “allocation by well test.” Flow sampling means the allocation of flow to different fields using a test separator, whereas allocation by well test means allocating total flow from a field to different wells using a test separator). To permit the use of a test separator for field allocation it may be necessary to enhance the test separator metering capability both in terms of the instrumentation used and in the operating procedures. Target uncertainties for allocation by flow sampling should be of the order of $\pm 5\%$.

6.5 Well Allocation Measurement

Accuracy of well flows are required to $\pm 5\%$. Where fluids produced from a pool are not directly measured at a well, the volumes produced should be estimated based on a flow calculation and allocation procedure which will permit a reasonable accurate determination of the fluids produced from each well in the pool. Monthly proration factors are expected to stay within the range of 0.95 to 1.05 for oil, water and gas. The operator is expected to investigate the cause of proration factors outside this range. As for field or platform allocation metering, following a request from the *Regulator*, operators will be required to report the cause and corrective measures being taken following repeated deviations outside the accepted ranges.

6.6 Fuel Gas, Gas Injection and Utility Gas

For fuel gas, gas injection and utilities the measurement is usually categorised as normal process quality measurement. The measurement uncertainty expected for this class of measurement is $\pm 3.0\%$.

6.7 Produced Water and Water Injection

The measurement uncertainty expected for produced water and water injection is $\pm 4.0\%$.

6.8 Drill Cuttings and Waste Fluid Injection

All fluids injected into a well should be measured. A relaxed measurement standard may be used for this purpose. The measurement uncertainty expected for this class of measurement is $\pm 15\%$.

7.0 Standards

Standards commonly used in the oil and gas industry for petroleum measurement are available from API, the BSI Group, the Energy Institute and ISO. The standards deal by their very nature with established methods and technology and offer no guidance as to best practice in the deployment of new and emerging technologies in the field of fluid flow measurement and allied topics. Operators should use the latest standards to guide and inform their discussions with the *Regulator* in arriving at a consensus view as to what constitutes *Good Oilfield Practices* in the specific context of the proposed development.

Facilities and operations are expected to meet the latest revision of the standards available at the time of approval and operators should assess subsequent changes to standards for impact to their operations. Guidance on standards that have been adopted or incorporated by reference in the regulations is provided in section 2 of the *Framework Regulations*. If an operator proposes to deploy a new technology in the proposed method of measurement for which no recognised standards exist then it will be necessary for the operator to identify any additional measures stemming from the risk assessments that have been undertaken. Refer to section 4.2 of this Guideline for additional guidance on introduction of new technologies.

8.0 Documentation Requirements

As per section 14 of the *Framework Regulations*, the operator of a field or terminal must apply to the *Regulator* for approval of the FSA, which includes the following:

- Flow System and Flow Calculation Procedure
- Flow Allocation Procedure

These procedures must be submitted and approved before an application for an authorization is approved which includes production from a field. Early communication is advised to avoid the operator proceeding with a system design that is unacceptable to the *Regulator*. The level of these discussions will only be available to the level of design complete at the time, but at the very least, the metering philosophy or concept level discussions would be expected.

8.1 Flow System

An application for approval of the flow system should include the following:

- schematics showing the location of all meters used in the measurement and allocation procedure and all streams which will be estimated rather than directly measured;
- specifications of the type, configuration and dimension of any meters and meter runs, meter proving equipment, sampling devices used to obtain fluid samples for determination of sediment and water content, devices to correct measured quantities of petroleum for temperature and pressure effects and devices for measuring temperature or pressure to be used in the flow calculation procedure;
- a description of each type of meter including:
 - flow rate range, operating temperature and pressure;
 - any measuring, sampling, monitoring or compensation device to be used in conjunction with the meter;
 - details of the operating conditions to which each meter will be subject including the range of flow rates, intermittent or continuous, the temperature and the maximum pressure drop across the meter; and

- details of the meter accuracy and a description of the proposed operating procedure including calibrations and checking of equipment for maintenance of accuracy; and
- a description of the test separators and the basis for selecting the capacity and quantity of test separators.

8.2 Flow Calculation Procedure

An application for approval of the flow calculation procedure should include:

- a description of the equipment, computer software and mathematical formulae to be used to convert raw meter output to a measured quantity of oil, gas or water;
- a description of the equipment, computer software and mathematical formulae and correlations of pressure, volume and temperature to be used to convert quantity of oil, gas or water at measured conditions to an equivalent volume at standard conditions for reporting purposes, or to estimate quantities of oil, gas and water in streams not directly measured;
- the frequency at which calculations will be made and an assessment of accuracy of the calculation algorithm including the effects of unintentional rounding errors for each metering location; and
- specimen calculations indicating how reported quantities of oil, gas and water are obtained giving correction factors proposed for converting meter and instrument readings to standard conditions.

8.3 Flow Allocation Procedure

An application for approval of the flow allocation procedure should include:

- proposed flow sampling or well testing procedures, duration and frequencies;
- a description of the equipment, computer software and mathematical formulae used in the allocation procedure;
- the accuracy capability of the allocation procedure including an analysis of the system measurement accuracy using the procedures established in the *API Manual of Petroleum Measurement Standards*;
- a description of the pools to which production will be allocated; and
- details of the procedure for allocating production to a typical well including a sample calculation with an explanation of each used and a schematic flow diagram showing the points at which the measurements were made.

8.4 Other submission requirements

In addition, the operator is requested to provide the following:

- A description of the organizational structure in place for the management of

the measurement system including responsibilities and the training and competency of personnel.

- The security provisions for changing any of the flow calculations and allocation procedures should be noted.
- A description of the procedures that will be used to estimate flow rates for those short periods of time when any meter may be out of service.
- A list of critical meters essential to the flow system which require operator notification to the *Regulator* when there is a failure.
- Sparing philosophies and list of spares to ensure the continued availability of meters and key instruments.

The list of spares should also be updated to reflect past operating experience. Refer to the requirements and additional guidance on asset integrity and maintenance programs under sections 153 and 159 of the *Framework Regulations*.

With respect to records and reporting requirements, refer to the requirements and associated guidance in the following sections of the *Framework Regulations*:

- For daily production records, refer to section 194.
- For daily reports, refer to section 197.
- For monthly production reports, refer to section 198.

9.0 Plant Balances

The operator is expected to maintain a plant balance for all fluids produced, injected, transferred, disposed of or used for fuel, gas lift or other utilities. In addition, for gas fields, the operator is requested to submit an overall plant balance on a monthly basis. The plant balance incorporates all offshore wells, platforms and custody transfer points.

10.0 Measurement of Liquid Petroleum

This Part of the Guideline is intended for use with liquid petroleum (e.g., crude, LPG, gas condensate) that is sufficiently above its vapour pressure and where there is no significant risk of gas breakout at the meter. Where this condition is not met, operators are strongly advised to exercise caution in applying the principles and advice provided here.

While this section of the Guideline focuses largely on mechanical type meters for measurement of crude, LPG and gas condensate, it is not meant to be restrictive of any other meter types that may achieve the required measurement accuracy. Prior to using newer technologies (for fiscal purpose) the operator should demonstrate to the *Regulator* that it is suitable for the intended application. Therefore, early dialogue is encouraged. *Regulator* approval of these technologies for fiscal applications is required prior to designing the flow system.

10.1 Fiscal Quality Measurement of Petroleum Liquids

10.1.1 Mode of Measurement

Hydrocarbon measurements should be reported in volumetric units and be measured in cubic metres. The overall level of uncertainty required for fiscal quality measurements of liquid petroleum is $\pm 0.25\%$. Fiscal quality measurement is required at points of custody transfer and at the export point of offshore production facilities in circumstances where the two are not a common measurement point.

The volumes should be referred to standard reference conditions of 15°C temperature and 101.325 kPa pressure. The metering system should compute referred volumes by means of individual meter temperature compensation and totalisers. Pressure compensation will always be required whether continuously or by a fixed factor determined at each proving as appropriate. Alternative systems giving equivalent results can be considered.

10.1.2 Meters and Associated Piping Systems

The meter should generate the electrical signal directly from the movement of the meter internals without any intermediate gearing or mechanical parts. Electronic interpolation systems may be accepted. Although the meters traditionally used for this service are either turbine or positive displacement meters, new types are available which if properly installed and operated can deliver similar levels of performance. Other considerations are as follows:

- **Number of Meter Runs** - A sufficient number of parallel meter streams should be provided to ensure that, at the nominal maximum design production rate, at least one stand-by meter is available, to maintain a high level of availability.
- **Isolation Valves** - Adequate valve arrangements should be provided such that individual meters may be safely removed from service without shutting down the entire metering system.
- **General Design and Installation Criteria** - Metering stations should have a common inlet header and, if necessary, a common outlet header to ensure uniform measuring conditions at all metering streams, temperature and pressure transducers and density meters. However if product of differing physical properties is produced by separate production trains and is not fully commingled before metering then it may be necessary to have separate measurement of the differing fluids.

10.1.3 Secondary Measurements

Temperature and Pressure Measurement

Temperature and pressure measurement points should be representative of conditions at the meter inlet and situated as close to the meter as possible without infringing the requirements of the *API Manual of Petroleum Measurement Standards*. In practice, this means approximately 5 diameters downstream of the meter location. Temperature measurements that affect the accuracy of the metering system should have an overall loop accuracy of at least 0.5°C, and the corresponding readout should have a resolution of at least 0.2°C. This is equivalent to an uncertainty of approximately 0.05% in C_{TL} (temperature corrected liquid volume). Thermo-wells should be provided adjacent to the temperature transmitters to allow temperature checks by means of certified thermometers. Pressure measurements that affect the accuracy of the metering system should have an overall loop accuracy of at least 50 kPa and the corresponding readout should have a resolution of at least 10 kPa.

Density Meters

Dual density meters should normally be used and include a density discrepancy alarm system. Where single density meter systems are used, high and low set point alarms should be used. Suitable sampling facilities should be provided in close proximity to the density meter(s) in all cases. Provision should be made for solvent flushing on systems where wax deposition may be a problem. Density meters should be installed as close to the volume flow meters as possible and be provided with thermo-wells and pressure indicators so that it may be demonstrated that there is no significant difference from the volume flow meters' inlet conditions. If this is not the case, temperature and pressure compensation should be applied. If the density meters are in a recirculation loop then the inlet probe should be a correctly designed sample take-off probe and positioned to extract a flow of representative composition.

10.1.4 Prover Loops and Sphere Detectors

Preferably, prover loops should be of the bidirectional type to eliminate possible directional bias. They should have a suitable lining. The flanged joints within the calibrated volume should have metal to metal contact and there should be continuity within the bore.

Connections should be provided on the prover loop to facilitate recalibration with suitable calibration equipment which may be a dedicated water draw tank or a portable calibration prover loop and transfer meter, or a small volume type prover.

Provers should be constructed according to the following criteria:

- Number of meter pulses generated over swept volume should be at least 20,000 pulses (This is equivalent to 10,000 pulses between detectors on bidirectional provers, or the equivalent accuracy greater than 1 pulse in 10,000 be achieved).
- Resolution of detector/displacer system to be compatible with the above.
- Displacer velocity not to exceed 3m/s to avoid slippage past the displacer but may be faster with piston type provers if seal integrity can be demonstrated.

Because the resolution of the detector/displacer system can only be gauged by the actual performance of the prover, the *Regulator* expects the manufacturer to demonstrate an acceptable repeatability during calibration of the prover, such that on 5 consecutive round trips the range of volumes does not exceed $\pm 0.01\%$ of the mean volume. Alternatively, a statistically equivalent repeatability criterion for small volume provers or meter pulse gating systems may be used.

For offshore use, or in remote locations, prover loops should be fitted with dual sphere detectors and switches at each end of the swept volume. At least two volumes should be calibrated so that failure of a detector or switch does not invalidate the prover calibration. The detector should be designed such that the contacting head of the detector protrudes far enough into the prover pipe to ensure switching takes place at all flow rates met with during calibration and normal operation. Detectors and switches should be adequately waterproofed against a corrosive marine environment. Refer also to the requirements and associated guidance for electrical, control and monitoring systems in sections 122, 123, 124, 125 and 169 of the *Framework Regulations*.

In the case of mechanical switches, each sphere detector should have a dedicated micro-switch. The actuation of each detector unit should be set during manufacture so that should it be necessary to replace a detector unit during service there will be a minimal change in prover calibrated volume.

NOTE: Other designs of prover may be considered subject to their being in accordance with Good Oilfield Practices. In the event of the failure of any critical element of the prover, the CCO should be contacted so that an appropriate strategy for the re-verification of the meters may be agreed.

10.1.5 Recirculation Facilities

Where recirculation systems are fitted around the metering system, full logging of recirculation and any other non-export flows through the meters should be maintained. Any such system should be properly operated and maintained.

Recirculation facilities intended for the use of pump testing, etc., should be fitted upstream of the metering system.

10.1.6 Pulse Transmission (PD and Turbine Meters)

The metering signals should be generated by a dual meter head pickup system in accordance with either Level A or Level B of *HM 23 Fidelity and security of measurement data transmission systems. Section 1: Electric and/or electronic pulsed data cabled transmission for fluid metering systems*. This is to indicate if signals are "good" or to warn of incipient failure of meter or pulse transmission.

A pulse comparator should be installed which signals an alarm when a pre-set number of error pulses occurs on either of the transmission lines in accordance with the above code. The pre-set alarm level should be adjustable, and when an alarm occurs it should be recorded on a non-resettable comparator register. Where the pulse error alarm is determined by an error rate, the error threshold should be less than 1 count in 10^6 . Pulse discrepancies that occur during the low flow rates experienced during meter starting and stopping should be inhibited. This is to avoid the initiation of alarms for routine process situations thereby tending to induce a casual attitude to alarms in general.

The pulse transmission to the prover counter should be from one or both of the secured lines to the pulse comparator, and precautions should be taken to avoid any signal interference in the spur from the comparator line. This is to ensure that meter factors are determined with quality pulses (i.e., as good as those pulses used to totalise production).

10.1.7 Totalisers and Compensators

Storage of Constants

All computer and compensating functions, other than data input conversions, should be made by digital methods. All calculation constants should be securely stored within the computer and should also be easily available for inspection at the appropriate resolution.

Each meter run should have an instrument computing uncorrected volumes at line conditions in which meter factors should be capable of being set to a resolution of at least 0.03% of value. In volumetric measuring systems, a liquid pressure correction may be included in the computation as this correction is usually small and of constant magnitude. Where a metering skid operates over a wide range of pressures as a routine then continuous correction for pressure effects may be appropriate.

Totalisers

Totalisers on individual meter run instruments and station summators should have sufficient digits to prevent rollover more frequently than once every two months. The resolution of the totalisers should be such as to comply with this rollover criterion. Totalisers should provide resolution sufficient to permit totalisation checks to be completed within a reasonably short time frame.

Totalisers and summators should be non-resettable and should be provided with battery driven back-up or permanent memories where they are of the non-mechanical type.

Flow computer manufacturers should consider the provision of a separate maintenance totalisation register for use during totalisation checks.

The procedures to be used for correcting flow during any period of mismeasurement should be made available.

For the volumetric mode of measurement, automatic temperature compensation should be applied. Temperature compensation should be carried out on each individual meter stream. The liquid thermal expansion coefficient should be fully adjustable over the range likely to be encountered in practice and have a resolution of at least 1%.

Corrections to meter throughput for water and sediment content should be applied retrospectively based on the analysis of the flow-proportional sample. However, it is recognised that the new generation of water-in-oil meters is approaching levels of performance associated with traditional methods and is likely to become acceptable within the currency of this document. Any application to use new methods will be reviewed on a case by case basis according to the policy for adopting new technology.

10.1.8 Other Instrumentation

To provide a history of meter operation and flowing conditions and a record of meter malfunctions, each meter-run should be provided with a continuous chart recording of flow rate and metering temperature. Alternatively, electronic data recording will be accepted provided that the recording frequency is adequate and the system logs all metering alarms. Recording intervals no greater than 4 hours will normally be considered adequate.

In mass measurement systems, the density signals from the density meters should also be recorded continuously by a chart recorder or electronic data recorder at the same interval as noted above. Digital read-outs should have a resolution of at least 4 significant figures.

Sampling System

Crude oil metering systems should be provided with automatic flow proportional sampling systems for the determination of average water content, average density and for analysis purposes. It is important to ensure that properly designed sample probes are used and positioned in such a way as to ensure representative sampling. Sample extraction rates should be “isokinetic” according to *ISO 3171*. These samples are required to account for dry oil quantities and allocated quantity determination. They may also be used for valuation purposes. In special circumstances when flows are specifically held constant (e.g., well testing) spot or time based sampling may be acceptable. The use of on-line water-in-oil monitors will be dealt with in accordance with the new technology procedures.

In crude oil systems where slugs of water may occur, in line water detection probes should be fitted to detect abnormal levels of water content. Continuous recordings of percentage water content and a high-level alarm system should be provided. Data from this source should not normally be used in determining dry oil quantities. This may only be used as a back-up in case of failure of agreed sampling and analysis procedures.

10.1.9 Security

In order to show if accidental or malicious interference with these critical components has occurred, all meter factor settings and reset buttons, where allowed, should be secured with a seal, lock or password to prevent unauthorized adjustment. Prover loop sphere detectors and associated micro-switches should also be secured by locks or seals.

Valves on re-circulation lines, provided for the purposes of off-line meter testing via re-circulation loops, should be provided with approved type locks.

10.1.10 Calibration Facilities

Adequate test facilities should be provided with metering systems to facilitate the checking and calibration of all computing and totalising systems. Test equipment must be calibrated in accordance with good measurement practices in accordance with paragraph 77(1)(b) of the *Framework Regulations*.

10.2 Field or Platform Allocation

Field or Platform Allocation denotes the accuracy required for the total flow from a system to be allocated to a single field or platform in a multi-field or platform development, where total flow is later measured further down the production stream by an approved fiscal quality meter, as described in section 6.1 of this Guideline.

A flow system that is a point of custody transfer may not support fiscal quality measurement. In this case, where fiscal quality would be normally required but has been exempted, then the lower quality measurement of field, platform or well allocation would be used for 'fiscal purposes'.

Two measurement scenarios (continuous and intermittent) are recognised in this situation, with continuous measurement being the most desirable. Early dialogue with the *Regulator* is encouraged such that the category of measurement can be agreed upon.

10.2.1 Continuous Measurement

Continuous measurement to an uncertainty not greater than $\pm 1.0\%$ should be applied for liquid hydrocarbons. Proration factors should stay within the range 0.99 to 1.01.

Dedicated separation and process trains with measurement capabilities to a high standard should be installed to meet these accuracies. The best levels of allocation metering can sometimes approach "fiscal" standards. In order to approach fiscal standards of allocation metering it would be necessary to have separate processing of the product streams.

Allocation metering systems approaching fiscal standards will in most cases use traditional equipment in the design of the metering system. The main difference from full fiscal metering standards is likely to be the removal of in-situ proving requirements. The meters would be installed on the outlet of the last separator stage and each train would be nominally identical. Fiscally metered production at the export or sales meter would then be prorated based on the allocation meter quantities.

This method has the advantage of reducing the effect of any systematic errors which may be present in the allocation metering system but are masked by the larger overall random uncertainties of the allocation meters.

In circumstances where it is not practicable to fully process the product streams then the next best option will be to place the allocation meters in the outlet pipework of the first stage separator. This option runs the risk of free gas being present in the product streams unless precautions are taken to ensure that the meters are installed in such a position where gas breakout is not likely to occur.

If the choice of allocation meter is not of the traditional variety but is for example a Coriolis or ultrasonic meter, particular care should be taken in matching the expected range of process conditions to the operational envelope of the selected meter type. These newer meters can be particularly sensitive to installation

effects or process conditions particularly if there is a risk of free gas being present in the product stream.

10.2.2 Intermittent Measurement

Intermittent measurement to an uncertainty not greater than $\pm 5.0\%$ should be applied for liquid hydrocarbons. Proration factors should stay within the range 0.95 to 1.05.

This scenario arises in situations which do not support the provision of dedicated separation and process trains, and the facility for continuous measurement. Under this scenario, allocation using intermittent or “flow sampling” techniques may be permissible. In most cases this will involve the use of a three-phase test separator. These tests are usually conducted at least twice per month. Ultimately, the frequency of the tests will be dictated by operating performance. In this regard, the *Regulator* may change the required testing frequency depending on whether or not proration factor tolerances are being met.

In the case of a new development where it is proposed at the outset to use a single production installation to co-produce more than one field then maximum advantage should be taken to make use of the opportunities afforded by a new-build situation to configure the process equipment to maximise the accuracy that the use of a test separator can provide.

Positioning the test separator within reach of the export meter prover may be possible. If that is the case then the small additional investment in a few metres of pipe and some valves offers the possibility of in-situ proving of the test separator meter(s). This, taken in conjunction with the selection of high quality instrumentation and flow computers, will result in the contribution to the overall uncertainty in the measurements used for allocation of the commingled out-turn by the meters being as small as practicable. The main contribution to the uncertainty will then arise from causes basically outside the operator’s control. These uncertainties stem principally from the variability of the process conditions in relation to flow rates, densities, water cut, incomplete separation, free gas in liquid streams, liquid carry over in gas streams, oil remaining in the water, etc.

In situations where the test separator measurement is used for fiscal purposes, one of the new generation of water in oil meters should be installed in the oil leg of the separator to reduce the error in dry oil accounting when the oil stream has significant water content.

If wells of significantly different physical properties and process conditions are to be allocated using flow sampling techniques then additional precautions will be necessary to ensure that each well is treated equitably in the allocation process. The pressure and temperature in the main production separators may be

significantly different from those obtained in the test separator during different well tests. This will result in a different test GOR from a production GOR. To compensate for this a process simulation should be run for each well on both the test separator and the main production separator. This will enable a correction or “shrinkage” factor to be determined. The use of such a factor should result in the sum of well head production being in closer agreement with the sum of the installation out-turn. Such adjustments have the merit of tending to reduce any systematic differences between wells of significantly different properties when using flow sampling for allocation purposes. This is particularly important if some of the wells are sub-sea completions tied back through long sub-sea flow lines.

In the circumstances where a new satellite field is to be co-produced using existing process equipment on a parent platform the scope for the operation of the test separator to the levels of accuracy achievable in the new-build circumstances described above is severely limited.

If an operator proposes to use an existing test separator to allocate production between different fields then it will be necessary to provide the *Regulator* with full engineering details of the test separator and its instrumentation in order that an evaluation can be made of its likely performance as an allocation flow sampler. In general it is unlikely that pipework modifications would be called for but where there is scope to enhance the metrology by upgrading instruments and flow computers this would normally be required.

Although the provision of permanent in-situ proving facilities for the test separator meters is unlikely to be feasible, consideration should be given to the proving of the meters in-situ using a portable small volume prover. It is recognised that there may be space and access restrictions that would make this approach impractical.

The allocation of the commingled production should be based on the principal of prorating the sums of the wellhead production (corrected if necessary for differences between test and production process conditions) from each contributing field. This procedure has the effect of minimising the impact that any undetected systematic errors might have on the equitability of the allocation.

In very exceptional circumstances, where the migration of uncertainties caused by relative flow rates and differing uncertainties of metering methods does not introduce unacceptable bias in the allocation of production, the use of difference methods may be permitted.

10.3 Well Allocation and Reservoir Management – Test Separator

Since the test separator may be called on to test wells exhibiting very wide differences in product quality, process conditions and flow rates it is unrealistic

to expect universally high standards of metering. The conditions ranging from steady flowing dry oil to slugging flow of high water content oil with significant amounts of produced solids as well as temperature variations from sea bed conditions to 100°C imposes severe limitations on the results achievable. In view of this a wide range of uncertainties is associated with this type of measurement. Typical target uncertainty is $\pm 5\%$. It is acknowledged that some installations with very favourable operating conditions may improve significantly on these figures.

While a conventional test separator may be equipped with a turbine meter or meters in the oil leg, orifice plate in the gas leg and magnetic flow meter in the water leg, there is scope for significant variations in test separator meter configurations. Operators might wish to consider whether coriolis, vortex shedding, ultrasonic or other meter types offer advantages in the provision of test separator meters.

The majority of wells are tested by diverting the well to be tested from the main production separator to the test separator for direct exclusive testing of the well. There may be circumstances where testing by difference may be a viable or even preferred option. Where circumstances permit there may be advantages particularly with subsea satellites for testing by difference. For developments where it is not necessary to provide for round trip pigging the elimination of a subsea test line may benefit the field economics.

Special precautions may be necessary when testing satellite wells connected to a parent platform by long subsea lines that when switching from production to test that the same flowing tubing head pressure exists under both test and production configurations. Failure to test the well under normal operating conditions will introduce additional errors to the test data.

11.0 Measurement of Gas

This Part of the Guideline is intended for use exclusively with single-phase gas. Where liquids or other contaminants are thought to be present, operators are strongly advised to exercise caution in applying the principles and advice provided here.

While this Part focuses largely on orifice meters for measurement of gas, it is not meant to be restrictive of any other meter types that may achieve the required measurement accuracy. Ultrasonic meters have made significant progress in this regard. However, prior to using these newer technologies the operator should demonstrate to the *Regulator* that it is suitable for the intended application. Therefore, early dialogue is encouraged. *Regulator* approval of these technologies is required prior to designing the flow system.

11.1 Fiscal Quality Measurement of Gas

11.1.1 Mode of Measurement

Petroleum or gas measurements for requirements pursuant to the regulations should be reported in volumetric units and be measured in cubic metres. The overall level of uncertainty required for fiscal quality measurements of gaseous petroleum is $\pm 1.0\%$. Fiscal quality measurement is required at points of custody transfer and at the export point of offshore production facilities in circumstances where the two are not a common measurement point.

All measurements should be reported in volumetric units and should be made on single phase gas streams. The volume reported should be referred to the standard reference conditions of 15°C temperature and 101.325 kPa absolute pressure (dry to the level specified in contractual specification).

Sampling

Suitable sampling facilities should be provided for the purpose of obtaining representative samples. This requirement may be influenced by the type of instrumentation incorporated in the measuring system. Additional guidance is provided in the *Data Acquisition Guideline*.

Gas Density

The continuous measurement of gas density is preferred but the density of the gas being metered may be computed from pressure and temperature measurements together with gas composition using a suitable equation of state and agreed computational techniques.

It is important that the gas entering the density meter is representative of the gas in the line, in respect of composition, temperature, and pressure. This becomes critically important if, as is generally the case, the pressure and temperature are not measured directly at the density meter.

Operators may therefore consider the use of density meters fitted with temperature elements, although the re-verification of these temperature elements may itself be problematic. No standard facility presently exists to measure temperature directly at the density meter.

Therefore, unless the temperature is measured directly at the density meter, equipment should be designed so that:

- The effect of ambient conditions (normally a cooling one) on the temperature of the gas sample is minimised. This may mean keeping the density meter inlet line in close thermal contact with the meter tube; ideally it should be

placed under any insulation. In extreme cases it may be necessary to heat-trace the line; in this case care should be taken not to over-heat the sample.

- There is no pressure drop between the density meter and the point in the system where pressure is normally measured. Therefore all isolation valves between the density meter and the pressure measurement point should be of the full-bore type.

Density meter installations should be designed so that, as well as meeting the above criteria, they also offer the facility for easy and efficient removal of densitometers and, preferably, the facility to readily view their serial numbers for auditing purposes.

11.1.2 Design Criteria

Where orifice meter systems are used, the design and operation should comply with *ISO 5167-1* but with the additional specifications given below. The following criteria should be used, however, other alternatives can be considered as long as the operator can demonstrate that the 1% target uncertainty is still achievable. Criteria is as follows:

- a) Maximum beta ratio 0.6.
- b) Maximum Reynolds number 3.3×10^7 .
- c) Maximum differential pressure of 50 kPa is preferred. Higher differential pressures may be used where it is demonstrated that the conditions of e), f) and g) are met.
- d) The metering assembly should be designed and constructed such that the minimum uncertainties specified in *ISO 5167-1* are achieved.
- e) The total deformation including static and elastic deformation of the orifice plate at maximum differential pressure should be less than 1%.
- f) The uncertainty in flow caused by total deformation of the orifice plate should be less than 0.1%.
- g) The location of the differential pressure tapplings with respect to the orifice plate should remain within the tolerances given in *ISO 5167-1* over the operating ranges of differential pressure transmitters. Where plate carriers utilise resilient seals care should be taken to ensure that the load on the plate caused by the maximum differential pressure does not move the plate out of pressure tapping tolerance.
- h) Special considerations may be applicable where pulsations are unavoidable but normally the uncertainty due to any such effects should be kept below 0.1%.

For existing metering systems, where orifice meters are employed, proposals to implement new or modified requirements contained within the current revision of *ISO 5167-1*, either partially or in full, should be discussed with the *Regulator* prior to implementation.

Where metering systems other than orifice plate metering are to be used, the systems together with their flow compensating devices, should be of the types agreed by the *Regulator* and should be calibrated over as much of the operating pressure, temperature and flow range as is reasonably practicable. Proposals for any extrapolation of such calibrations and correlations of the operating conditions should be presented.

Meter Runs

Sufficient meter runs should be provided to ensure that, at the maximum design field production rate or utility rate, at least one stand-by meter is available. Due consideration should be given to the provision of adequate valves so that individual meters may be removed from service without shutting down the entire metering system.

Secondary Instrumentation

Secondary instrumentation, line pressure and temperature, differential pressure, flowing density, density at base or reference conditions where appropriate and the flow computers should be specified and their positions in the system should be located such that representative measurement is ensured. In many applications the compositional analysis of the gas is required and it is necessary to provide for gas sampling or on-line analysis.

Consideration should be given during the design of a measurement system for the provision of back-up instrumentation to cover the failure of normal instrumentation, and also for the provision of suitable facilities for the on-site calibration of secondary metering equipment.

Avoidance of Liquid Carry-Over

Metering stations should be designed to be free from any carry over into the metering section, and from any condensation or separation that would have a significant effect on measurement uncertainties.

Overall Design Accuracy & Measurement Uncertainty

An indication of the overall design accuracy and measurement uncertainty of the metering system together with the sources of error should be given in accordance with *ISO 5167-1*. The assessment of uncertainties in gas measurement should be calculated in accordance with *ISO 5167-1*.

11.1.3 Computers and Compensators

Dedicated Flow Computers

A flow computer should be dedicated to each meter run. Alternatively if multiple meter runs are computed by one machine a hot operating standby should be provided to allow maintenance or replacement to be carried out without interruption of flow.

Storage of Constants

All computer and compensating functions, other than data input conversions, should be made by digital methods. All calculation constants should be securely stored in the computer and should be easily available for inspection. Equipment should be designed so that constants can be adjusted, but only by authorised personnel. After initial agreement of stored constants, as included in the FSA, subsequent changes in the computer should be made only with agreement of the *Regulator*. Where it is necessary to use manual inputs of data into the computer, (e.g., base density), the use of this data should be automatically logged.

Flow computers and databases should be designed so that measurement accuracy is not compromised by inadequate resolution on the display of critical constants.

Totalisers

Totalisers on individual and station summators should have sufficient digits to prevent rollover more frequently than every two months. Totalisers should normally have a resolution of 1000 standard cubic metres, or decimal submultiples thereof. Totalisers and summators should be non-resettable and where they are of the non-mechanical type should be provided with battery driven back-up or permanent memories.

Where external totalisers or summators are not installed, the resolution of the flow computer totalisers should be such as to comply not only with this rollover criterion, but also allow totalisation tests to be performed to the required tolerance. These totalisers should also be non-resettable. If the resolution of the totalisers cannot meet both the rollover and totalisation test requirements, consideration should be given to the provision of a totalisation test function within the flow or database computer.

Flow computer manufacturers should consider the provision of a separate 'maintenance' totalisation register for use during totalisation checks.

Compensation for influencing parameters, such as pressure and temperature, should be carried out in the flow computer by digital methods using approved algorithms.

If it is proposed to use new technology such as time of flight ultrasonic meters then details of the proposed equipment, layout and verification procedures should be discussed with the *Regulator* at the earliest opportunity.

Consistency Within Systems

In a gas gathering system the operator responsible for the gathering should ensure that the basic metering data, flow formulae and computational techniques are compatible throughout all the fields connected to the gathering system.

Calorific Value Determination

The average heating value (energy per unit volume, flow weighted average) of custody transfer gas, if applicable, should be reported to the *Regulator* monthly. Provision for the determination of the calorific value of custody transfer gas should be made.

Requirements for Notification of Regulator

With respect to subsection 77(a) of the *Framework Regulations*, the *Regulator* will require notice of the factory inspection and calibration of primary and secondary equipment, including flow computers, in order that conservation officers may witness these tests at their discretion.

Adequate verification or, where appropriate, calibration equipment should be provided to enable the performance of meters, computers, totalisers, etc., to be assessed. Reference or transfer standards should be certified by a laboratory with recognised traceability to national standards.

Requirements for transfer meter calibration are provided in section 77 of the *Framework Regulations*.

11.1.4 Calculation of Design Uncertainties

When using orifice plate meters according to *ISO 5167-1*, over normal production flowrates the overall uncertainty should be better than $\pm 1.0\%$.

In the case of differential pressure transmitters, it is important to use realistic field values as the choice of uncertainty value has an impact on the operational turndown of the system and also on the setting of the changeover point(s) for

metering systems incorporating both high and low range transmitters.

11.2 Field or Platform Allocation

Field or Platform Allocation denotes the accuracy required for the total flow from a system to be allocated to a single field or platform in a multi-field or platform development, where total flow is later measured further down the production stream by an approved fiscal quality meter, as described in Section 6.1 of this Guideline.

A flow system that is a point of custody transfer may not support fiscal quality measurement. In this case, where fiscal quality would be normally required but has been exempted, then the lower quality measurement of field, platform or well allocation would be used for 'fiscal purposes'.

Continuous measurement to an uncertainty not greater than $\pm 3.0\%$ should be applied for gas production. Proration factors are expected to stay within the range 0.97 to 1.03.

11.2.1 Dry Gas Measurement

For the purposes of this section the term "dry gas" is taken to mean gas which is at a temperature sufficiently above the dew point that condensation does not occur in the meter tubes upstream of the principal flow measuring element or within the downstream section of pipe between the principal element and the sample take-off point.

In circumstances where the fiscal status of production from different fields using common process or transportation infrastructure does not call for full fiscal quality metering it is normal to refer to the class of measurement system as "allocation" metering. Care should be taken to differentiate between the *process* of allocation where fiscal quality measurement may be required and the *class* of measurement frequently referred to as "allocation metering" where relaxed standards of measurement may be appropriate.

Uncertainties for dry gas allocation metering systems will be $\pm 3.0\%$. In order to achieve this level of uncertainty the basic design of the metering station will be similar to a fiscal quality metering station. The relaxed level of uncertainty is achieved through simplified procedures for the operation and periodic verification of the metering system.

If a multi-path ultrasonic meter is the preferred instrument in a particular application it may be possible depending on the circumstances to dispense with a redundant meter run. The multi-path nature of such instruments may be deemed to provide the required level of redundancy. In order for such a

configuration to be accepted it would be necessary to demonstrate that the loss of accuracy suffered by the failure of one chord does not take the system outside the agreed uncertainty and that a spare set of transducers is available to enable full operational capability to be reinstated within a reasonable time.

If it is proposed to operate a single stream metering system the ability to change transmitters under pressure should be fully assessed. If for safety or operational reasons it is not possible to replace transmitters under pressure then suitable isolation valves upstream and downstream of the meter should be provided and the impact of such a configuration on the ability of the installation to meet daily nominations when it is necessary to work on the meter be recognised.

If the proposed allocation metering system is to be installed on an unattended installation then in order to ensure the required level of availability and to avoid unscheduled visits to the installation it may be necessary to include an appropriate level of redundancy in the instrumentation associated with the meter(s).

11.2.2 Wet Gas Measurement

For the purpose of this section, “wet gas” is interpreted to mean gas that is in equilibrium with either water or gas condensate or both in the flowing gas stream. It is not intended to address the measurement of gas with a sufficient liquid content to be deemed two phase flow. The precise value of the LGR defining wet gas or two phase boundary cannot be stated as it will depend on process variables such as gas velocity, water/condensate ratio, line temperature and pressure. As a guide LGRs greater than about 0.2% for stratified flow and 0.5% for annular mist flow are likely to require two phase flow measurement techniques.

The types of meter presently considered suitable for wet gas metering are: orifice plates with drain holes, venturis, v-cone meters and ultrasonic meters.

Special precautions over and above those required for dry gas will be necessary in the design and operation of any meter to be used in wet gas.

Venturi meters should be designed and installed broadly in accordance with *ISO 5167-1*.

If an operator chooses to meter wet gas using a venturi, the arrangement of bottom pressure tappings quoted in *ISO 5167-1* should not be used as this could result in liquid finding its way into the impulse lines of the pressure and differential pressure transmitters. Single pressure tapping on the top of the meter would normally suffice.

When any differential pressure device is used to measure wet gas, corrections should be applied to the discharge coefficient to take account of the liquid content. The methods of Murdock⁵ and Chisholm⁶ as modified by Jamieson and Dickenson⁷ may be used to correct for the effect of liquid content.

As present work to correlate the difference between calculated pressure recovery and measured pressure recovery as a function of liquid content holds the promise of a direct on line measurement of liquid content, all new developments should provide a pressure tapping at the recovered pressure position in the downstream section of the metering tube. This small pre investment offers the prospect in the near future of measuring the LGR continuously on line at a negligible cost.

Operators of existing wet gas metering systems should consider whether the potential benefits of such a system warrant the retrofitting of a suitable pressure tapping.

If wet gas allocation meters are to be installed on unattended installations redundant instrumentation should be utilised to minimise the need for unscheduled visits to the installation while providing a high level of availability.

11.3 Well Allocation and Reservoir Management – Test Separator

Since the test separator may be called on to test wells exhibiting very wide differences in product quality, process conditions and flow rates it is unrealistic to expect universally high standards of metering. The conditions ranging from steady flowing dry oil to slugging flow of high water content oil with significant amounts of produced solids as well as temperature variations from sea bed conditions to 100°C imposes severe limitations on the results achievable. In view of this a wide range of uncertainties is associated with this type of measurement. Typical target uncertainty is $\pm 5\%$. It is acknowledged that some installations with very favourable operating conditions may improve significantly on these figures.

If the test separator measurement constitutes part of the total platform measurement then it will require measurement uncertainties in line with those required for field or platform allocation that is uncertainty not greater than $\pm 3.0\%$ should be applied for gas.

Traditional instrumentation may still be the favoured option for gas field test separator operations. However, if wet gas allocation metering is also to be used on the installation, then the use of the test separator to determine LGRs takes on an additional importance as well as the reservoir management function.

⁵ J W Murdock, Two-Phase Flow Measurements with Orifices. Journal of Basic Engineering 1962.

⁶ D Chisholm, Two Phase Flow Through Sharp Edged Orifices. Research Note. Journal of Mechanical Engineering Science 1977.

⁷ A W Jamieson and P F Dickenson, High Accuracy Wet Gas Metering. North Sea Flow Measurement Workshop 1993.

11.4 Utility, Gas Injection and Fuel Gas Measurement

Where gas is used for utility purposes such as gas lift, oxygen stripping and power generation or for gas injection or acid gas disposal, process quality measurement will generally be considered adequate. The level of measurement uncertainty considered appropriate for this class of measurement system is $\pm 3\%$. It will normally be considered sufficient for a single measurement point to be used to account for all utility consumption (but not including gas injection). However, for operational reasons, the operator may wish to have separate metering for each consumption unit on the installation. This will be acceptable to the *Regulator*. Details of the selected measurement system should be included in the documentation sent to the *Regulator* for review.

If the gas used on an installation does not originate from the field being produced by the parent platform other procedures may be required.

In circumstances where a satellite field is produced using the process equipment of a parent installation, then a method of accounting for the amount of gas used in producing a satellite should be provided. In some cases this may involve the provision of dedicated measurement equipment. It may also be possible to account for individual field usage based on the relative proportions of service required. This may take into account such factors as throughput, pumping or gas compression requirements, water treatment or injection requirements and any other service which involves the use of gas in its provision.

If an installation is gas deficient and it is necessary to import gas from a pipeline system for power generation and utilities use then it will normally be necessary to have a "fiscal quality" metering system to account for gas imported as the pipeline will be transporting "fiscally" metered gas.

Gas transported between two installations via a dedicated pipeline for use on the importing platform for utilities purposes may, depending on the fiscal status of the exporting installation, make use of less-than-fiscal quality measurement.

11.5 Flare or Vent Gas Measurement

Flare gas is to be measured or calculated. Vent gas should be measured or otherwise accounted for. In recent years significant advances have been made in the technologies of flare gas measurement. Operators are encouraged wherever practical to measure the quantities of gas vented from an installation. The uncertainties likely to be achievable in flare gas metering systems will be of the order of $\pm 5\%$ for high pressure flare systems and $\pm 10\%$ for low pressure flare systems.

Refer to the requirements and associated guidance for gas flaring and venting under sections 82 and 83 of the *Framework Regulations*.

12.0 Multiphase Petroleum

The ability to meter to a satisfactory degree of uncertainty oil, gas and water in multiphase mixtures without recourse to expensive separation is perhaps the greatest challenge facing the oil and gas measurement industry.

This Part is intended to provide operators with guidance on the relevant considerations regarding the potential application, selection, operation and re-verification of multiphase meters.

Any operator contemplating the use of multiphase metering should make contact with the *Regulator* at the earliest possible stage.

The acceptability of a multiphase meter for a particular development will depend in large measure on the match between the instrument's operating characteristics and the anticipated 'in-service' process conditions. It may in some circumstances be necessary to implement a technology qualification program to assess the suitability of a meter for a particular set of process conditions. Refer to the guidance provided in section 4.2 of this Guideline.

12.1 Fiscal Quality Measurements of Multiphase Petroleum

Multiphase metering is not the preferred option for fiscal measurement applications. This is mainly due to difficulties in achieving the desired levels of uncertainty and the high costs of in-situ meter re-verification for marginally economic fields.

12.2 Field or Platform Allocation

The first task when considering the use of a multiphase meter for allocation purposes is to decide the levels of uncertainty which are appropriate for each phase. This will depend on the value of the phase and the production rate. Clearly a highly accurate measurement on a phase comprising only a few per cent of the production is unlikely to be either cost effective or necessary. The accuracy with which the hydrocarbon flows can be determined will take precedence over the accuracy of water flows. However, water fraction measurement may have a high significance depending on the absolute value of the water cut in any particular multiphase flow.

At present the "universal" multiphase meter covering all flow regimes and all possible phase proportions from 0% to 100% of oil, water and gas does not exist. Consideration should be given at the outset to the possible need to use different

types of multiphase meters at the start of production than those that may be required at different stages in the life of the field. A detailed evaluation of the predicted production profiles in terms of the changes to GOR and water cut expected over the life of the field will give some indication of the possible changes in multiphase meters which should be planned.

As these instruments at present have large uncertainties there is a risk that significant systematic errors could be masked by the overall random uncertainties. When considering the use of these meters, good repeatability is an important consideration particularly where the opportunity exists for in-situ calibration. By considering other measurement points throughout the production and transportation system procedures can be devised to establish if any bias exists and steps taken to eliminate it as part of the initial verification. If such opportunities do not exist within the basic design of the production facilities then modifications should be considered to enable verification tests to be performed.

It is not practicable to suggest what verification provisions should be made in this document, as any such provision will of necessity be tailored to the particular type of instrument and the process environment in which it is installed.

12.3 Well Allocation

There are a number of options for the use of multiphase meters for well testing. Potential benefits include the elimination of test separators or reduced well test time and frequency of well tests. Subsea satellite developments with long subsea test flowlines may also benefit from this technology. These benefits will only be available if the individual fields' process characteristics are amenable to such treatment. Depending on pipework configuration and deployment strategy of multiphase meters another potential benefit is continuous well monitoring or failing that, frequent well monitoring at daily intervals.

Topside use of multiphase meters may be either on their own or in conjunction with a test separator. A multiphase meter in each well flowline may provide a satisfactory level of well management information without the need for a test separator although such an arrangement makes the extraction of well samples more difficult. In some instances a test separator may be required for multiphase meter calibration and well sampling.

If it is proposed to dispense with a test separator and rely entirely on multiphase metering for well testing then care should be taken to ensure that the full range of process conditions presented by wells is within the performance envelope of the selected meter. If flow rates from the range of wells to be managed by the system is very wide then it may be necessary to install more than one meter to provide cover for the full range of flows and process conditions likely to be encountered. As one meter or type of meter may not cover the range of

conditions which may arise throughout the life of the installation consideration should be given at the outset to the possible need to change either the size or type of instrument needed.

In the case of sub-sea satellite clusters the choice of individual well meters or a single meter on a test manifold should be considered. If the properties of the process fluid are such that round trip pigging is not required the saving of a subsea test line can be significant compared to the costs of sub-sea multiphase meters.

12.4 Standards

Refer to *API Manual of Petroleum Measurement Standards Chapter 20.3 Measurement of Multiphase Flow*.

Reporting Meter Performance

It is essential when considering a manufacturer's performance and accuracy statements to understand the implications of accuracy's quoted in different ways. There are three common ways in which multiphase meter accuracies are presented:

- a) % phase volume flow rate
- b) % total multiphase flow rate
- c) % gas and liquid flow rate plus absolute uncertainty of water cut in liquid phase

Method a) is favoured by metrologists and clearly represents performance as stated. This method may not be the most practical for extreme cases of phase fractionation. Methods b) and c) while quoting relatively small numbers of the order of 5% to 10% for gas/liquid phase uncertainties and 2% or 3% for percentage water cut may nevertheless exhibit very large individual phase errors of 100% or more depending on the absolute value of the percentage water. A useful guide to multiphase metering is to be found in the *Handbook of Multiphase Metering produced by the Norwegian Society for Oil and Gas Measurement*.

13.0 Produced and Injected Water

Where water is produced in association with oil or gas or injected into a reservoir for pressure maintenance or disposal purposes process quality measurement will generally be considered adequate. The level of measurement uncertainty considered appropriate for this class of measurement system is of the order of $\pm 4\%$. Details of the selected measurement system should be included in the documentation sent to the *Regulator* for review.

In terms of allocation of water production to individual wells an accuracy of $\pm 5\%$ is considered reasonable.

14.0 Drill Cuttings and Waste Fluid Injection and Measurement

All waste fluids injected into a well should be measured. Examples of waste fluid include drill cuttings and mud. Details of the selected measurement system should be included in the documentation sent to the *Regulator* for review.

In terms of allocation of drill cuttings and waste fluid injection to individual wells an accuracy of $\pm 15\%$ is considered reasonable.

15.0 Operating Procedures

15.1 Hydrocarbon Liquid Measurement Systems

These procedures cover the metering of hydrocarbon liquid volume with particular emphasis on crude oil measurement and are based on the operational characteristics to be expected of a typical metering station equipped with turbine meters. Where other types of meter have been approved, a variant of these procedures may be appropriate. The performance of individual metering stations will depend on the particular characteristics of both the metering system and flow system and the type of hydrocarbon being metered: therefore deviations from these procedures may be necessary in special cases, for example measurements on very viscous crude oils, or low lubricity fluids such as gas condensate.

Operators are required to submit their proposals for the operation and calibration of their metering systems to the *Regulator* prior to the commencement of commissioning and operation.

15.1.1 Prover Calibration

Prover loops should be calibrated at the manufacturer's works by methods described in API or ISO standards as part of their systems checks and following installation on site. Two copies of the calibration certificates for each of these and all subsequent calibrations should be sent to the *Regulator*. Certificates should be submitted to either the C-NLOPB at information@cnlopbc.ca or to the CNSOPB at info@cnsopb.ns.ca. Such certificates should show the reference numbers of the sphere detectors used in the calibration and the traceability to national standards of the calibration equipment. Meters and associated equipment should also be calibrated as described in Part 14 of the *Oil and Gas Conservation Regulations of Alberta*.

While a metering station is in service, prover loops should be calibrated at a frequency of not less than once a year. Where this is not possible for operational

or weather reasons, a two-month period of grace will be allowed. Operation beyond this period requires dispensation from the *Regulator*.

For small/marginal fields, or fields that are in decline and producing at a rate that is only a fraction of the rate originally approved in the development plan (i.e., reduced custody transfer/offload frequency), the *Regulator* may consider extending the prover calibration interval beyond 12 months provided the following conditions are met:

- The five most recent prover calibrations demonstrate that each calibrated volume has remained within a range of $\pm 0.02\%$ of its mean over these five calibrations.
- The five most recent prover calibrations demonstrate that the shift in each calibrated volume, from the first to the fifth calibrations, is within $\pm 0.02\%$.

Operators wishing to pursue the possibility of extending their prover calibration beyond 12 months, and whose systems meet the above criteria, should contact the *Regulator* to discuss the matter more fully.

Inspection of all critical valves and instrumentation along with the sphere, checking of sphere size, sphericity, etc., should take place prior to calibration. After calibration, the sphere detectors and switches should be sealed.

Any maintenance work on the prover that could affect the swept volume (e.g., changes of sphere detectors and switches) should not be undertaken without prior notice to the *Regulator* which will advise if a recalibration is required.

Pursuant to section 78 of the *Framework Regulations*, the *Regulator* must be given at least 30 days' notice of all prover loop calibrations so that arrangements for witnessing can be made.

15.1.2 Determination of Meter Characteristics

For new or modified meters which are to be operated over a wide flow range covering flow rates below 50% of maximum, characteristic curves of meter factor versus flow rate should be determined for each meter. These curves should cover a range of approximately 20% to 100% of maximum flow rate, subject to any system restriction on flow rate. From these curves the permissible flow rate variations at a given meter factor setting will be determined.

Meters that are to be operated normally only at above 50% maximum flow rate, except during starting and stopping, will not be subject to the above requirement provided it can be shown that a meter factor variation of not greater than 0.1% occurs over the working flow rate range.

15.1.3 Meter Proving in Service

The requirements governing the intervals between turbine meter proving are:

- For a newly commissioned metering station in a continuous production system (as distinct from tanker loading), meters should be proved three times a week at approximately equal intervals between proving. Provided the meter factor scatter is acceptable to the *Regulator*, this frequency may be reduced to twice a week at the end of the first month and once a week at the end of the second month.
- For tanker loading systems, the frequency of proving will depend on the duration of the loading and the individual production system characteristics. Generally, proving should be done once during tanker loading operations, when flow has stabilized.

Meters should also be proved:

- a) When the flow rate through the meter changes by a significant amount. This change in flow will depend on the gradient of the meter's flow characteristics in any particular installation and would normally be such that a change in meter factor greater than 0.1% does not arise from the change in flow rate. If the change in flow rate is a scheduled long term change then the meter(s) should be reproved at the first opportunity. If the flow rate change is unscheduled then the meters should be reproved if the estimated duration of the changed flow is six hours or more.
- b) When any significant change in a process variable such as temperature, pressure or density of the liquid hydrocarbon occurs for extended periods as for flow in a) above that is likely to cause a change in meter factor of 0.1% or more. Practical values of these limits are of the order of 5°C temperature, 1000 kPa pressure and 2% density.
- c) If scale or wax deposition occurs then a higher frequency of proving may be necessary until the deposition problem can be overcome.

Where meter types other than turbine meters are in use, the type and frequency of meter factor proving by the operator will be determined on an individual basis by the *Regulator* after consultation with the operator. Account will be taken of the meter type, process fluid and operational load cycle. Where meters employing novel technology are to be used, extra evaluation periods and tests will usually be required before acceptance of a long term operational schedule can be determined.

15.1.4 Meter Factors

Meter factors should be based on the average of at least five proof runs. All consecutive five proof runs should lie within $\pm 0.05\%$ of the mean value. Full

details of the proof runs, together with flow rates, pressures and temperatures should be entered in the record of meter proving.

In particularly difficult situations where process stability sufficient for proving purposes cannot be achieved, then a special proving regime may be agreed after consultation with the *Regulator*. The purpose of a non-standard proving regime is to arrive at a good average meter factor that represents the meter's performance under unstable operating conditions. In seeking to determine a meter factor under unstable process conditions it is acknowledged that a significant proportion of the variability in meter factors is not due to the meter's intrinsic repeatability but to the variations in process conditions during the meter proving.

On metering installations where the meter factor is set manually, the change in factor should be done in such a way as to prevent loss in the measured flow. Also, the new factor setting should be checked by a second person who should sign to this effect in the record of meter proving.

15.2 Gaseous Measurement Systems

These procedures cover the metering of petroleum in the gaseous phase. They will also be appropriate for gas at high pressure when it is sometimes referred to as a "dense phase fluid". These procedures primarily address orifice plate metering stations. Many of the provisions will be applicable to metering stations employing other measurement technologies with variations as appropriate.

Operators are required to submit their proposals for the operation and periodic verification of their metering systems to the *Regulator* prior to the commencement of commissioning and operation. These will include proposed calibration intervals for the ancillary instrumentation.

15.2.1 Pre-Commissioning

The operator should prepare a schedule of pre-commissioning tests that are designed to demonstrate the operability of salient aspects of the metrology as detailed within *ISO 5167-1*. In particular, there should be an examination of the interior of the meter tubes and of the orifice plates to ensure that they conform to the relevant provisions of the standard.

15.2.2 Start-up Precautions

If there is a risk that debris including dust, mill scale or other foreign matter may be present in the process upstream of the meters then consideration should be given to the use of "start-up" plates to avoid damage to the primary elements for long term metering service. Instruments that may be susceptible to damage or

malfunction if exposed to foreign matter should be isolated from the process for the first 24 to 48 hours after start-up. Instruments most likely to be affected are densitometers and gas chromatographs. During this period the flow computers should preferably use a default gas composition to calculate the gas density at operating conditions or use a keypad value of gas density representative of the operating conditions. The computer should be returned to “live input” density as soon as the clean-up is complete.

15.2.3 Differential Pressure Measurement

Differential pressure transmitters should be calibrated at high static pressure representative of the normal operating pressure for the instrument. When this is not possible, high static calibrations should be performed at a suitable calibration facility and subsequently “footprinted” at atmospheric pressure for use in periodic verifications offshore. As facilities are not available locally for this technique, the overall uncertainty in metering accuracies should take into account effects related to calibration at different static pressures.

15.2.4 Ancillary Instrumentation

Detailed procedures for the verification of ancillary instrumentation such as pressure, temperature, gas chromatography, density and relative density where appropriate should be prepared for review by the *Regulator*.

Sampling systems for product characterisation may use conventional methods or where appropriate on-line gas chromatographs.

Calibrations should be carried out using test equipment that is dedicated to the metering systems and is traceable to national standards.

The recalibration frequency for each component in the system should be included in the procedures document. It is expected that initially the calibration frequency for most components will be monthly. As a history of the stability of the instrumentation is built up it may be appropriate to increase the intervals between recalibrations. As this would constitute a change in the “method of measurement” prior consent should be sought by the operator before any relaxation of calibration procedures can be granted. In order to support such an application it will be necessary to show that the instruments remain within tolerance on a number of successive recalibrations and are returned to service in the “as found” condition.

The *Regulator* may consider a recalibration schedule based on “health checking” procedures in circumstances where signal data analysis systems are in place to monitor the condition of the instrumentation and indicate when an instrument is moving out of its specification. Notification to the Regulator should be provided

if an operator wishes to adopt such procedures. This should include an analysis of the impact such procedures would have on the overall uncertainty of the metering system.

When calculating the overall uncertainty of metering installations, operators should use realistic “field” values for the uncertainties of the ancillary instrumentation rather than the manufacturers’ claimed values. The uncertainties claimed by manufacturers for their equipment is usually the best the equipment is able to deliver under ideal laboratory conditions.

In the case of differential pressure transmitters it is important to use realistic field values as the choice of uncertainty value has an impact on the setting of the changeover point for systems with high and low range transmitters.

The tolerances used when recalibrating ancillary instrumentation should be set at a level which, while not being so tight as to make their achievement under field conditions extremely difficult, should not be so lax as to risk compromising the overall target uncertainty for the class of measurement in question.

When density is calculated from a compositional analysis and process conditions of pressure and temperature using an approved equation of state, the accuracy of the ancillary instrumentation has an additional significance. Typical sensitivities of calculated density to process variables are:

Variable	Change	% Change in Density
Pressure	1%	1.0
Temperature	1°C	0.7
Molecular Wt	1%	1.6

15.2.5 Inspection of Orifice Plates and Meter Tubes

The interval between successive orifice plate inspections should initially be one month.

Once it has been established that plate contamination is not likely, this interval may be extended after consultation with the *Regulator*. A typical inspection sequence, assuming that the condition of the plates is satisfactory on each occasion, might be:

- Six plate inspections at one-month intervals
- Two plate inspections at three-month intervals
- Two plate inspections at six-month intervals
- Annual plate inspection

On plate contamination being encountered, the inspection frequency should

automatically revert to the previous stage in the above sequence. Plates should, however, be inspected following an operational upset that could cause damage to the plates.

When carrying out an examination of an orifice plate in the field it is not necessary to conduct a full gauging examination to *ISO 5167-1* tolerances. The main points to look for in a field inspection of an orifice plate include plate flatness, cleanliness, freedom from damage to the plate surfaces and particularly damage or rounding of the sharp edge.

It may, from time to time, be necessary to examine the condition of the meter tubes in pressure differential metering systems (orifice plate or venturi) to ensure that corrosion, erosion or contamination has not occurred to an extent likely to affect the accuracy of the meter. These examinations may be considered necessary if periodic plate examinations show persistent contamination. Particular attention should be paid to the section extending two pipe-diameters upstream of the orifice plate and to the condition of the penetration of the pressure tappings through the meter tube wall. If flow conditioners are used these should also be examined.

15.2.6 Other Meters

Where meters other than orifice meters are used such as turbine meters or multi-path ultrasonic meters singly or in combination and appropriate operating and verification procedures should be discussed at the design stage with the *Regulator*.

15.3 Multiphase Measurement Systems

Operators should discuss the details of their proposed operating procedures at an early stage with the *Regulator*. All opportunities for periodic verification should be investigated. This is likely to involve plans to make use of scheduled shutdowns of contributing production streams to establish continued satisfactory operation of the meter. Plans should also be in place to make opportunistic use of unscheduled shutdowns to provide supporting evidence of meter performance.

As the technology is developing rapidly, operators should keep a watching brief on developments that may refine their instrumentation capability through increasingly sophisticated signal-processing techniques. As our understanding of multiphase metering advances, there is significant scope to use advanced signal processing techniques to get more and better information from the existing multiphase metering hardware.

15.4 General Procedures

Metering stations should be operated and maintained in accordance with the manufacturers' recommendations. Particular attention should be paid to flow stabilisation prior to meter proving and checking of block and bleed valves for leaks.

The temperature-compensated totals associated with the individual meters are to be used as the basis of the approved measurements at each metering station.

15.4.1 Documentation at the Meter Station

The operator should maintain a log book (either manual or *Regulator* approved electronic form) for the prover detailing all calibrations, sphere detector serial numbers and any maintenance work done on the prover loop and its associated equipment.

A manual or *Regulator* approved electronic log should be kept for each meter showing details of:

- type and identifying particulars including location and product measured;
- totaliser reading(s) on commencement of metering;
- all mechanical or electrical repairs or adjustments made to the meter or its read-out equipment;
- metering errors due to equipment malfunction, incorrect operation etc., including date, time and totaliser readings both at the time of recognition of an error condition and when remedial action is completed;
- alarms, together with reasons;
- any breakdown of meter or withdrawal from normal service, including time and totaliser readings;
- replacement of security seals when broken; and
- record all re-circulation activities.

The operator should also keep a record of meter proving for each meter giving the full details of each proof run. This record may be kept in either hard copy or *Regulator* approved electronic form and should include a running plot, or similar control chart, so that any undue change or fluctuation in meter factors may be easily detected.

A manual log or automatic recording should also be kept, at intervals of not more than 4 hours, of the following parameters:

- all meter totaliser readings;
- meter flow rates (also relevant meter factors), pressure and temperature, and (if measured continuously) density; and
- any change in meter pulse comparator register readings.

One of these sets of readings should be recorded at 24:00 hours, or at the agreed time for taking daily closing figures if different.

Other parameters such as liquid density and percentage BS&W content should be recorded at agreed intervals, if not already included in the automatic log.

Records of parameters such as meter flow rate, liquid temperature and density should be kept at the metering station for at least four months.

All above records should be available at all reasonable times for inspection by a conservation officer.

15.4.2 Direct Reporting to the Regulator

Pursuant to subsection 77(2) and sections 162 and 170 of the *Framework Regulations*, operators must notify the *Regulator* prior to any major maintenance or re-calibration work on the metering and proving system. The *Regulator* should also be notified when any abnormal situation or error occurs which could require significant adjustments to the totalised meter throughputs.

If a flow meter is required to be removed or replaced, a notification should be sent to the *Regulator* detailing the serial numbers of the meters concerned and the reasons for the action taken.

When corrections to meter totalised figures are required due to known metering errors, a report should be submitted to the *Regulator* detailing the times of the occurrence, totaliser readings at start and finish, required corrections to these readings, and reasons for the errors occurring.

In the event of a flow meter failure, the *Regulator* should be notified in accordance with the process outlined in the *Incident Reporting and Investigation Procedure*. The written notification should include details of remedial actions being taken, including the procedure used to estimate volumes while the meter is out of service. The *Regulator* or conservation officer should be notified when the situation has been rectified and the flow meter has been repaired/replaced and is functioning properly.

16.0 Bibliography

1. *A W Jamieson and P F Dickenson, High Accuracy Wet Gas Metering. North Sea Flow Measurement Workshop 1993*
2. *API Manual of Petroleum Measurement Standards (multiple volumes with varying dates of issue)*
3. *C-NLOPB/CNSOPB, Data Acquisition Guideline*
4. *C-NLOPB/CNSOPB Incident Reporting and Investigation Guideline*
5. *D Chisholm, Two Phase Flow Through Sharp Edged Orifices. Research Note. Journal of Mechanical Engineering Science 1977*
6. *Energy Institute, HM 23 Fidelity and security of measurement data transmission systems. Section 1: Electric and/or electronic pulsed data cabled transmission for fluid metering systems*
7. *Handbook of Multiphase Metering, Norwegian Society for Oil and Gas Measurement, March 2005*
8. *ISO 3171 Petroleum liquids - Automatic pipeline sampling, 1988*
9. *ISO 5167-1 Measurement of fluid flow by means of pressure differential devices inserted in circular cross-section conduits running full – Part 1: General principles and requirements, 2003*
10. *J W Murdock, Two-Phase Flow Measurements with Orifices. Journal of Basic Engineering 1962.*
11. *United Kingdom's Department of Energy and Climate Change, Oil and Gas Office Guidance Notes for Standards for Petroleum Measurement Under the Petroleum (Production) Regulations, December 2003, Issue 7.*